

“Clean profile” cylinders to ISO 15552 standard Ø 32 ÷ 100

series X

1

DESCRIPTION

Cylinders series “X”, and their fixing accessories, comply with ISO 15552 standard, being in this way completely interchangeable with the former cylinders to ISO 6431/VDMA 24562 standard. They are available in the bores from Ø 32 to Ø 100 with techno-polymer piston as standard. The cylinder barrel, made in extruded aluminium alloy, has some “T”-slots on three sides where it’s possible to mount directly the magnetic sensors series “FM100”. Upon request, cylinders series “X” comply with ATEX directive, 2GD category. Thanks to proper cover strips that give the cylinders a really clean profile, the cylinders result suitable also for difficult environments like the food one. A further feature is the possibility to assemble some series of valves directly on the cylinder barrel thanks to the brackets type “X/P/M” (see page 1.24).



TECHNICAL DATA

Operating pressure	1 ÷ 10 bar
Working temperature	0 ÷ +80 °C (-35 °C with dry air) 0 ÷ +150 °C with seals for high temperature (-10 °C with dry air)
Fluid	Compressed air, filtered, continuous lubricated, unlubricated or dry lubricated
Versions	Double acting, single acting front spring, single acting rear spring, through rod, double push tandem, double stroke tandem, opposed tandem
Bore	Ø 32, 40, 50, 63, 80, 100
Port size	Ø 32 = G 1/8 Ø 40 - 50 = G 1/4 Ø 63 - 80 = G 3/8 Ø 100 = G 1/2
Standard strokes (mm)*	25, 50, 75, 80, 100, 125, 150, 160, 200, 250, 300, 320, 350, 400, 500, 550, 600, 650, 700, 800, 900, 1000
Decelerators lenght	Ø 32 40 50 63 80 100 mm 24 29 29 35 35 40
Maximum stroke (mm)	Ø 32 ÷ 100 = 3000; versione T, P, V = 1000
Max. stroke single acting (mm)	Ø 32 ÷ 63 = 50, Ø 80 - 100 = 100
Spring theoretical tractive force	See technical data on page 0.13

*Cylinders, with strokes shorter than the decelerators lengths, are NOT cushioned as standard.

MATERIALS

End caps	Painted die-cast aluminium alloy
Cylinder barrel	Extruded profile, 20 µm anodized aluminium alloy
Screws	Steel (self-forming)
Piston rod	C45 chromium-plated steel AISI 303 rolled stainless steel
Rod nut	Steel Stainless steel
Piston rod bearing	Bronze-iron 20%, sintered, self-lubricating
Piston	Techno-polymer (with or without magnet) Aluminium alloy (with or without magnet): for high temperatures, for applications without the effective use of the cushioning and for strokes over 1000 mm.
Seals	Polyurethane FKM (Viton®)
Cover strips	Polyvinylchloride
Spring	Spring steel

ORDER KEY

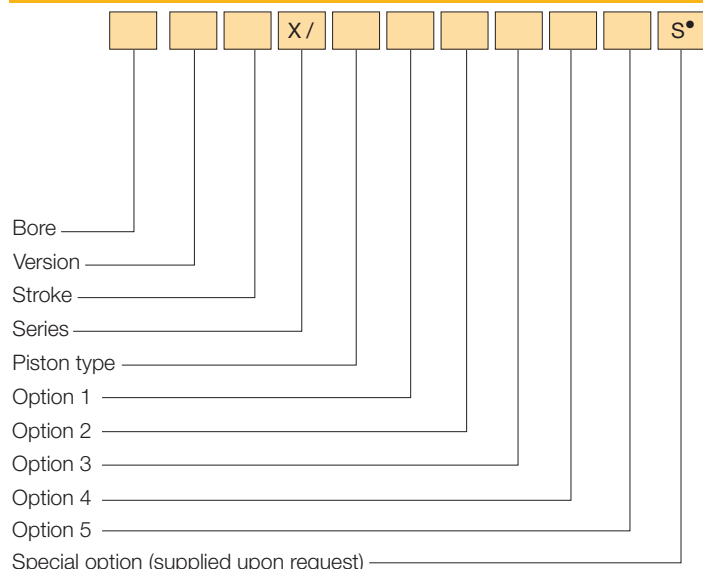

• See chapter 1, page 1.1.

ORDER EXAMPLES

Cylinder Ø 50, double acting, 100 mm stroke, non-magnetic piston type, fit for piston rod locking unit: **50/100 X/NZ**

Cylinder Ø 63, through rod, 150 mm stroke, magnetic piston type, stainless steel piston rod with cover strips: **63R150 X/M14**

Cylinder Ø 80, double stroke tandem, 50 mm stroke 1 + 100 mm stroke 2, magnetic piston type: **80P50+100 X/M**

VERSION

/ Double acting	T Double push tandem*
S Single acting front spring	P Double stroke tandem
Y Single acting rear spring	V Opposed tandem
R Through rod	

PISTON TYPE

N Non-magnetic	M Magnetic**
----------------	--------------

OPTION 1

Z Fit for piston rod locking unit***

OPTION 2

1 Stainless steel piston rod and rod nut	3 Stainless steel piston rod and rod nut and seals for high temperatures*
2 Seals for high temperatures*	

OPTION 3

4 Cover strips for magnetic sensors slots***

OPTION 4

5 Aluminium alloy piston

OPTION 5

/EX Consistent with the ATEX directive Ex II 2GD c T5 T100°C -35°C ≤ T_a ≤ 80°C

* Supplied only with aluminium alloy piston.

** Available even with “FKM” (Viton®) seals but just for applications where is needed a chemical compatibility; not available for high temperatures and ATEX.

*** Don't use it for high temperature application and ATEX.

SPARE PARTS

SEALS KIT

Polyurethane	Ø/SG/X
Through rod polyurethane	Ø/SG/R/X
For high temperatures	Ø/SG/X2
Through rod for high temperatures	Ø/SG/R/X2

1

X BASIC CYLINDER

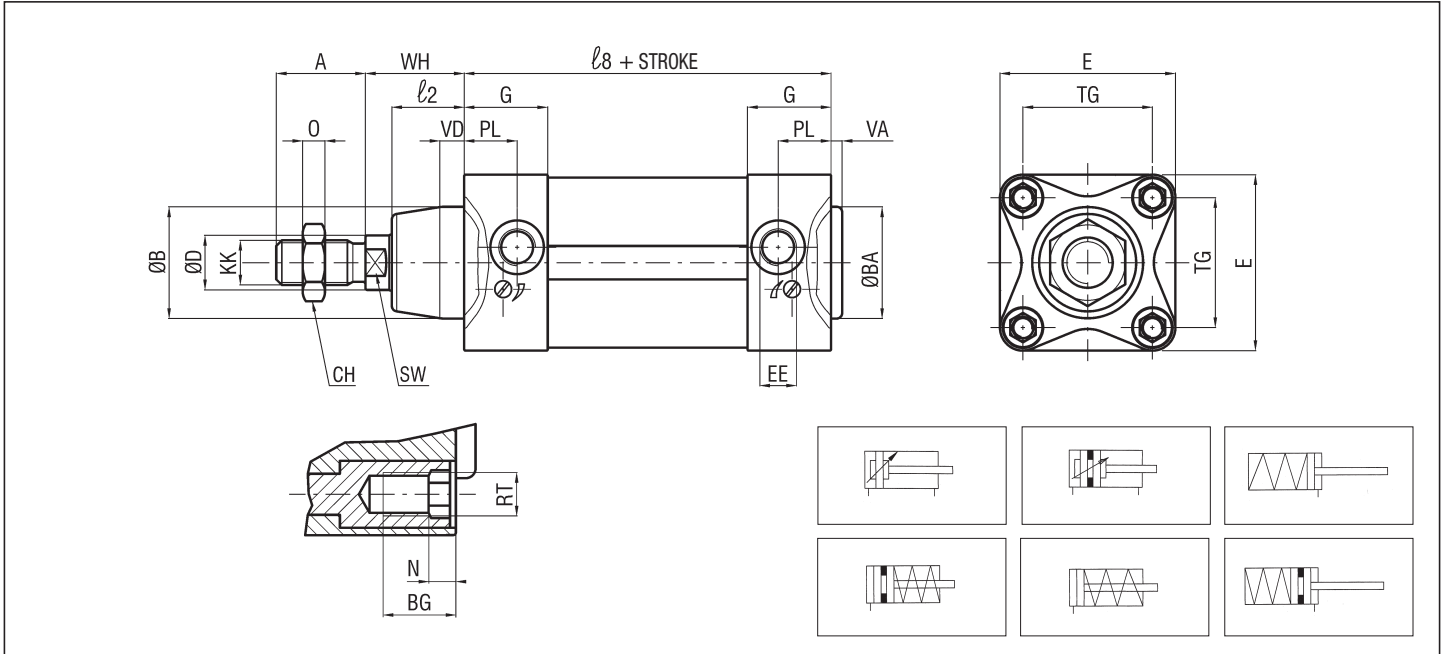

P.S.: Rod nut supplied as standard

DIMENSIONS AND WEIGHTS BASIC CYLINDER

\varnothing	A*	BA* B*	BG*	CH	D	E*	EE*	G	KK*	l	$l2^*$	$l8^*$	N	O	PL*	R	RT*	SW*	TG*	VA* VD*	WB	WH*	WEIGHT (g)	INCR. (g) every 10 mm
32	22	30	16	17	12	47	G1/8	27	M10x1,25	175	20	94	5,5	6	18	9	M6	10	32,5	3	86	26	555	31
40	24	35	16	19	16	52	G1/4	31	M12x1,25	201	22	105	5,5	7	20,5	9	M6	13	38	3	100	30	809	41
50	32	40	16	24	20	63	G1/4	30	M16x1,5	191	26	106	5,5	8	19	9	M8	17	46,5	3	127	37	1178	59
63	32	45	16	24	20	75	G3/8	35,5	M16x1,5	217	27	121	6,5	8	22	9	M8	17	56,5	4	127	37	1683	60
80	40	45	16	30	25	93	G3/8	36	M20x1,5	240	29	128	6,5	9	23	9	M10	22	72	4	156	46	2683	92
100	40	55	16	30	25	113	G1/2	39	M20x1,5	258	35	138	6,5	9	24	9	M10	22	89	4	161	51	3645	96

* STANDARDIZED DIMENSIONS

THROUGH ROD

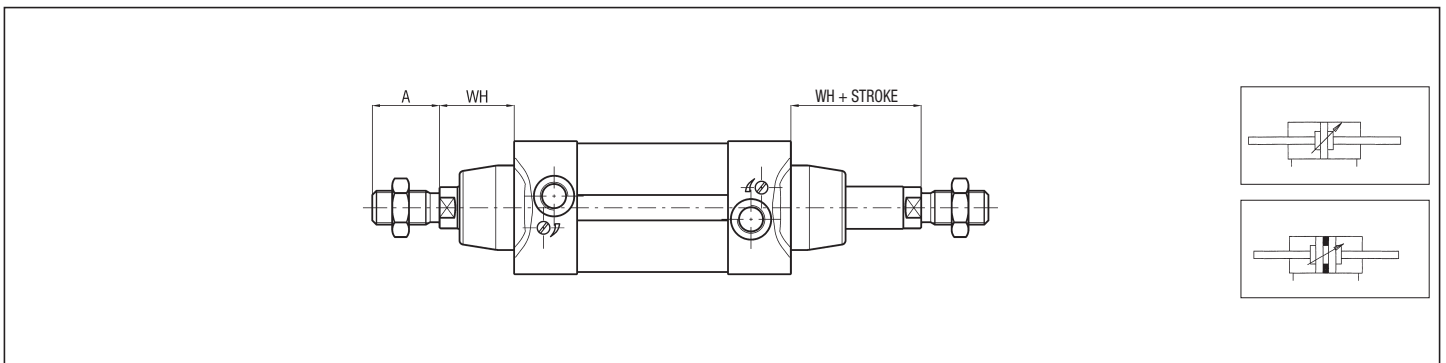

P.S.: Rod nut supplied as standard

DOUBLE PUSH TANDEM

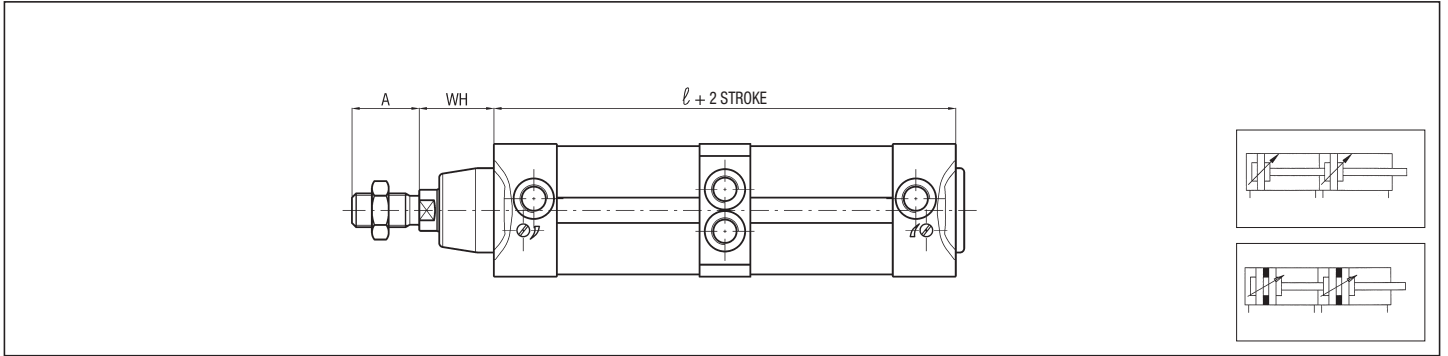

P.S.: Rod nut supplied as standard

DOUBLE STROKE TANDEM

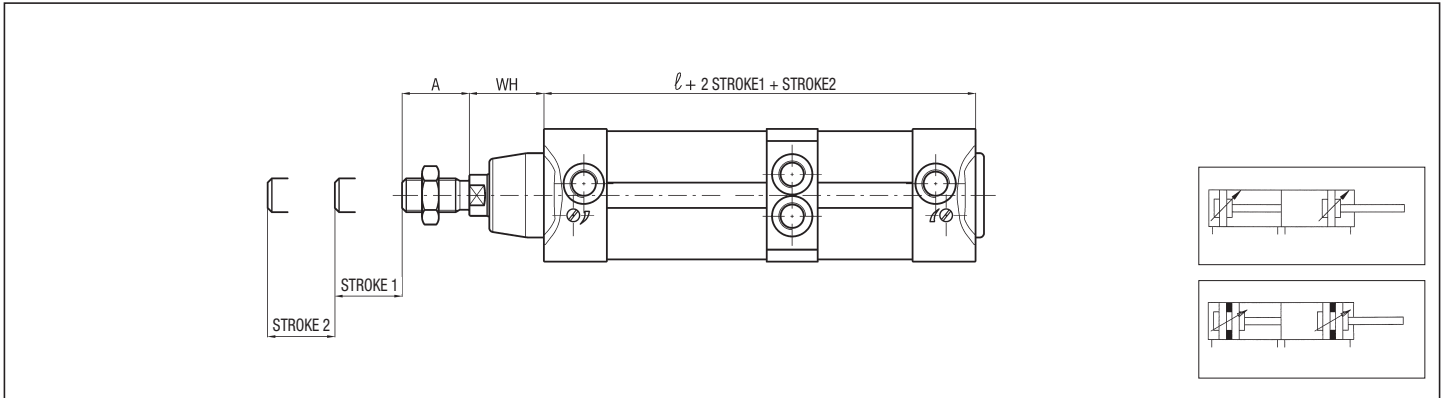

P.S.: Rod nut supplied as standard

OPPOSED TANDEM

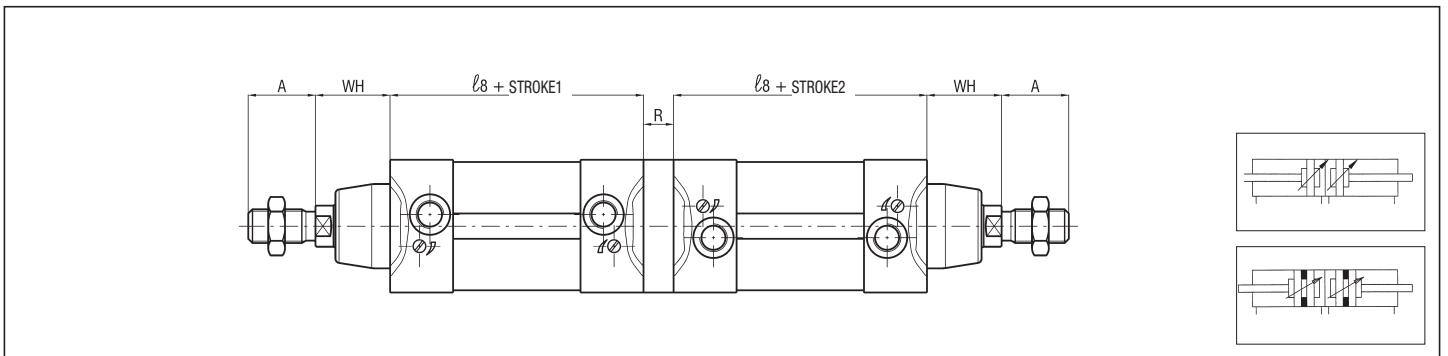

P.S.: Rod nut supplied as standard

FIT FOR PISTON ROD LOCKING UNIT

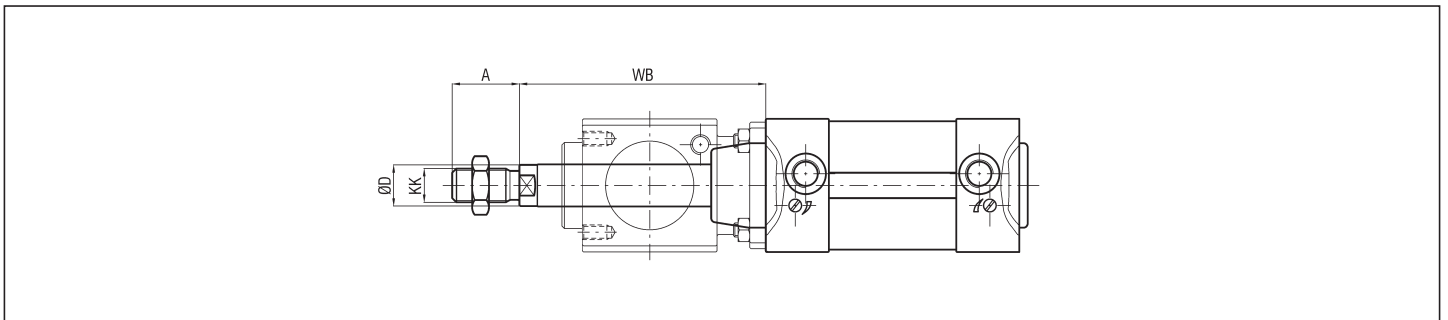

P.S.: Rod nut supplied as standard

1

SMALL SLOT COVER STRIP - X/CP

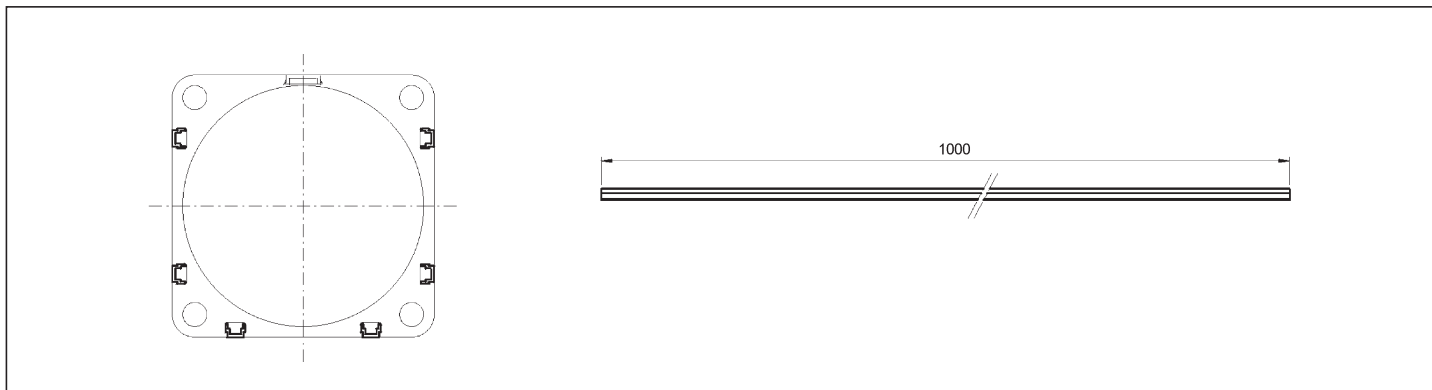

BIG SLOT COVER STRIP - X/CG

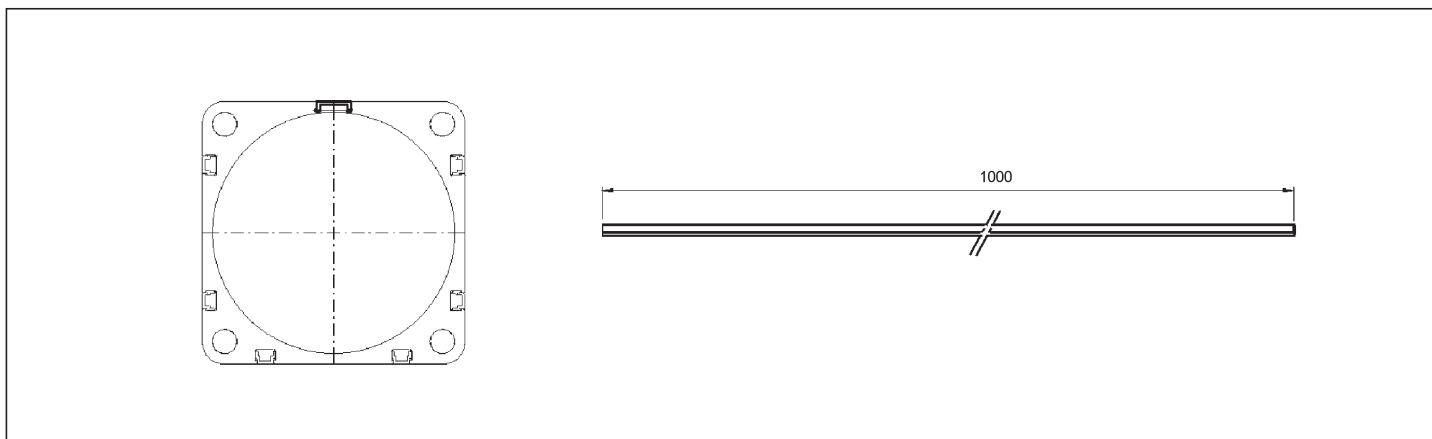

FIXING BRACKETS FOR TEE-SLOTS - X/P/M..

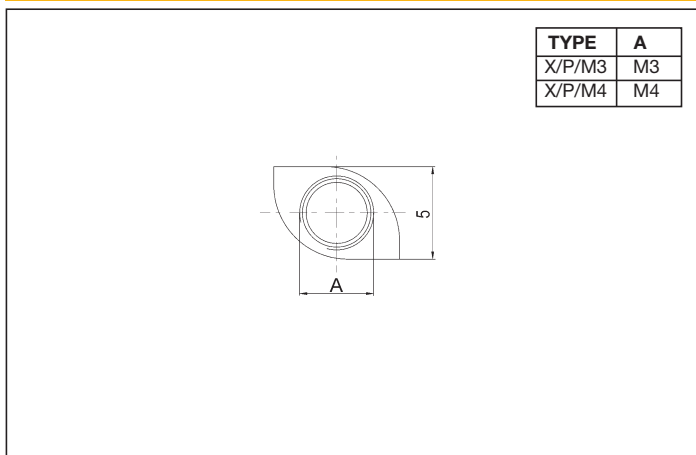

EXAMPLE OF ASSEMBLING OF VALVES MEV-MEK/CYLINDER

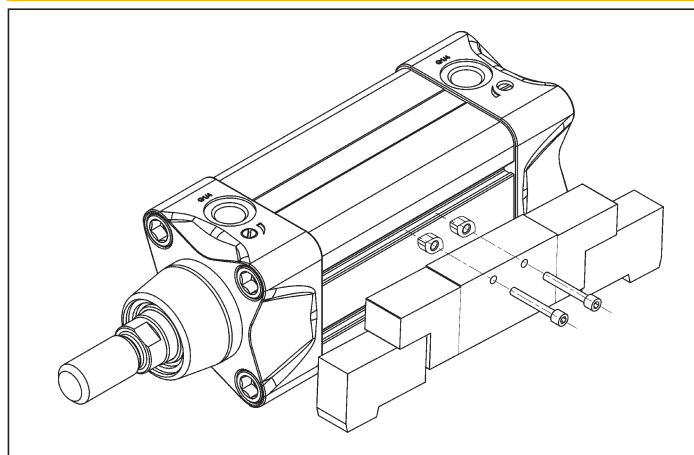

TECHNICAL INFORMATION FIXING BRACKETS

These brackets, with vertical insertion, allow to assembling directly on the cylinder barrel some series of valves and can be used even as reference point for the replacement of magnetic sensors.